

SPECIFICATION

产品规格书

REFOND P/N 产品型号

RF-MTB652T05-A1

R&D 研发

Mass Product 量产供货

Contents 目录

1. Product Description/ 产品描述	3
2.Product Specification / 产品规格	4
2.1 Optical-electrical Characteristics(Absolute Maximum Ratings At Ts=25℃)/ 产品光电特性.	4
2.2 Product Schematic And Interface Definition/产品电性规格	5
2.3 Product Module rule of naming 产品命名规则:	5
3. Product Specification /产品规格	6
3.1 Outline Dimension /外形图	6
4. Product Reliability Test/产品可靠性实验	7
5. Product Materials Performance Test And Method At Ta=25℃/产品物料性能检测和方法	8
6.Packing Criterion/包装标准.....	9
6.1 Package Diagram /包装示意图	9
6.2 Carton silk printing/纸箱丝印.....	9
6.3Label Form Specification/标签规格	9
7. Handling Precautions 产品使用注意事项	10



REFOND

1. Product Description/ 产品描述

high reliability and high safety;

★ 可靠性，安全性高；

2835 LED Package, high lighting efficiency, low heat, without Mercury, belong to the environmental protection cold light source;

★ 2835LED光源，光效高，热量低，不含汞，属于环保冷光源；

The protection of the lamp is up to IP67, with beautiful appearance, no fouling situation.

★ 灯具防护等级高达IP67，外表美观，无积灰等现象；

Designed for normal and low temperature refrigeration walk-ins and display case applications;

★ 专为常温和低温制冷步入式和展示柜应用而设计；

Ideal for C-Stores, Grocery, and Big Box Retailers.

★ 商店，杂货店和大型零售商的理想选择。

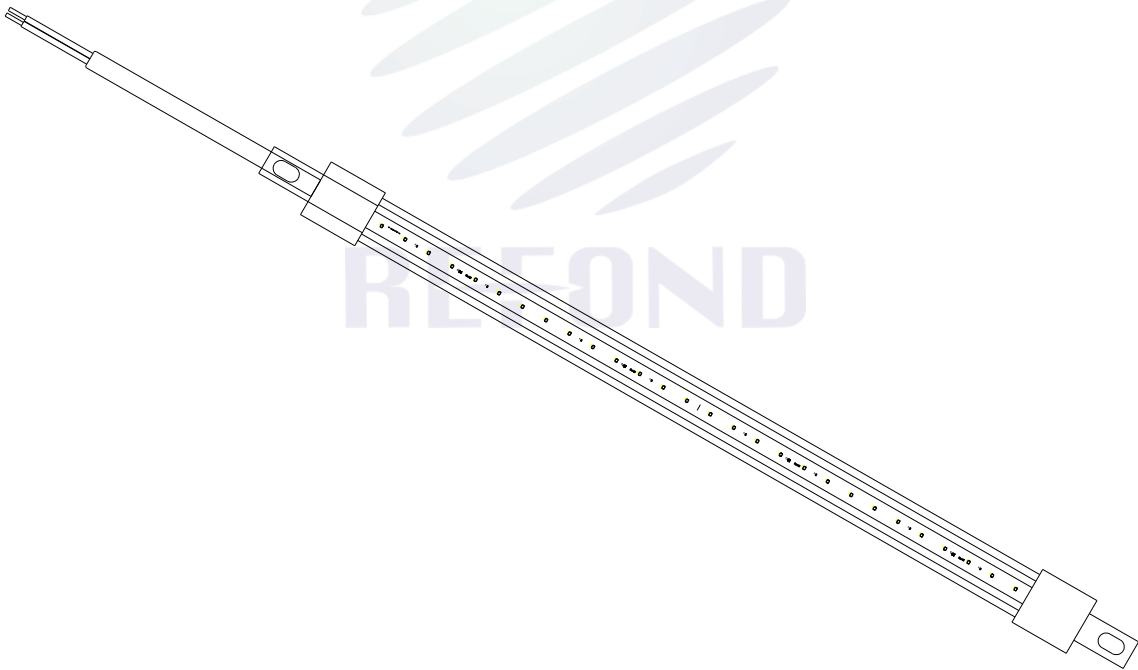

2.Product Specification / 产品规格

2.1 Optical-electrical Characteristics(Absolute Maximum Ratings At Ts=25°C)/ 产品光电特性

Tab.2-1 Optical-electrical Characteristics 产品光电特性

Refond PN 瑞丰产品料号	Customer PN 客户料号	产品参数Module Characteristics				
		电流Current (mA)	电压 Voltage(V)	功率 Power(W)	产品光通量 Module LM	
		Typ	Typ	Typ	Min	Max
RF-MTB652T05-A1 (6000-6500K)	-	205	24	5±8%	625	700
Color Rendering Index (显指)	≥80	测试条件(V)Test condition		Typ		
		24		24		
产品色容差为(MacAdamElipsis)				≤5		

Tab.2-2 Absolute Maximum Ratings at Ts=25°C产品相关参数绝对最大值

Parameter (参数)	Symbol (符号)	Rating (值)	Units (单位)
Forward Current (正向电流)	I _F	205±8%	mA
Peak Forward Current (峰值电流)	I _{FP}	268	mA
Reverse Voltage (反向电压)	V _R	5	V
Electrostatic Discharge (HBM) (静电)	E _{SD}	2000	V
Operating Temperature (操作温度)	T _{OPR}	-40 ~ +85	°C
Storage Temperature (储存温度)	T _{STG}	-40 ~ +100	°C
Junction temperature (单颗 LED 结温)	T _J	115	°C

2.2 Product Schematic And Interface Definition/产品电性规格

Fig.2-2 Product connection 产品电性图

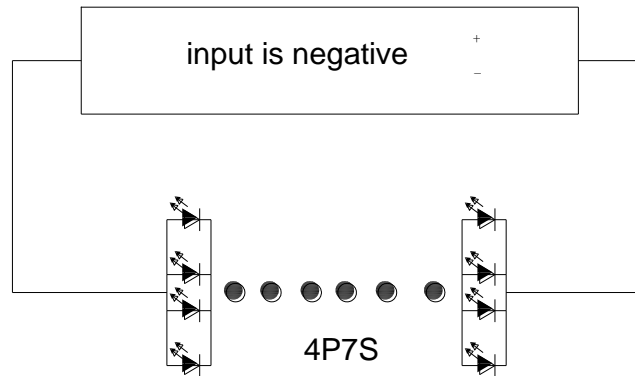

2.3 Product Module rule of naming 产品命名规则:

RF - MT B 65 2 T 05 - B 1

- 瑞丰版本号 (1 : 第一版本)
Refond version number (1: the first version)
- 产品方式 (B : 直下式)
Product emitting light way (B: Top view)
- 产品功率 (05 : 产品功率 5W)
Product power: (05:Product is 5W)
- 产品显色指数 (H: 85≥T>80)
Product CRI (H: 85≥T>80)
- LED 型号 (2: 2835)
LED Package type (2: 2835)
- 产品色温 (65:6000-6500K)
Product CCT (65:6000-6500K)
- 产品类型 (B: 冰柜灯)
Product type (B: Freezer lights)
- 模组部代码
Module department code
- 公司简称代码 (RF: 瑞丰)
Refond company abbreviation (RF: Refond)

3. Product Specification /产品规格

3.1 Outline Dimension /外形图

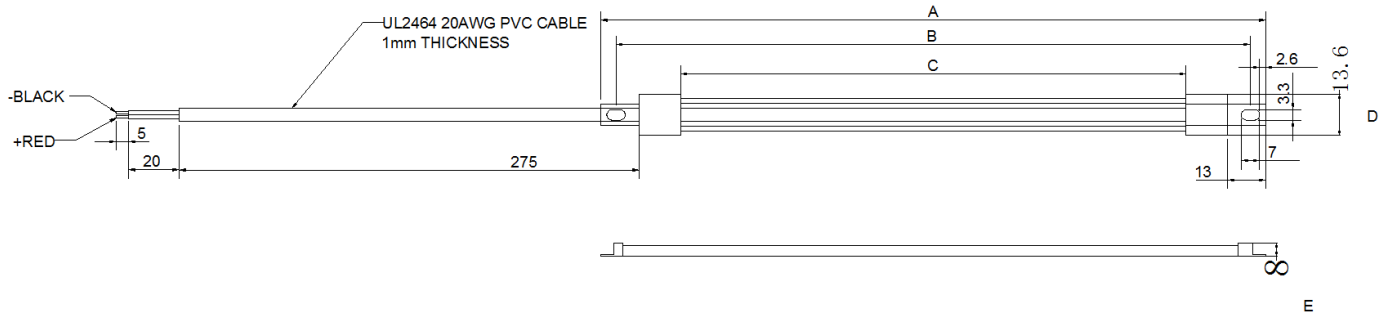

	Dimension 尺寸
A	1029±5mm
B	1016±5mm
C	980±5mm
D	13.6±1mm
E	8±1mm

REFOND

4. Product Reliability Test/产品可靠性实验

Tab 4-1 Light Bar Reliability Test 灯条可靠性实验

Test Item/ 测试项目	Test Conditions/ 测试条件	Test Time/ 测试时长	Number Of Test/ 测试数量	Judgement Criteria/判 定标准
Operating Life At Room Temperature/ 常温测试	$T_A=25^{\circ}\text{C}$ $I_F=250\text{mA}$ $T_J<115^{\circ}\text{C}$	500Hrs	0/6	1. $\Delta\Phi<30\%$, $V_f<110\%$, $\text{CIE}\Delta x/\Delta y<0.015$ 2.No catastrophic failure
Operating Life At High Temperature/ 高温测试	$T_A=60^{\circ}\text{C}$ $I_F=250\text{mA}$ $T_J<115^{\circ}\text{C}$	500Hrs	0/6	
Operating Life At High Temperature And Humidity/ 高温高湿测试	60°C $R_H=90\%$ $I_F=250\text{mA}$ $T_J<115^{\circ}\text{C}$	500Hrs	0/6	
Thermal Shock/ 冷热冲击	-40°C 15min $\uparrow\downarrow 10\text{S}$ 85°C 15min	100 cycle	0/6	No DeadLED

Notes 备注：

voltage distribution, heat dissipation and others.以上可靠性测试是基于瑞丰现有实验平台单颗/条 LED 在良好散热条件验证下的结果。客户端将 LED 应用于串、并联线路时，需自行评估电流、电压分配、散热等问题。

5. Product Materials Performance Test And Method At Ta=25°C/产品物料性能检测和方法

Tab 5-1 Light Bar Materials Performance Test And Method Ta=25°C 灯条物料性能检测和方法

Test Item/项目	Test Conditions/指标	Test Methods/测试方法
LED Optical-electrical Characteristics/LED 光电参数	Compliance With Specifications/ 符合规格书	Integrating Sphere/ 积分球测试
Connector Pull Force/ 连接器推拉力	≥7kgf	Notes/ 见备注
LED Push & Pull Force/ LED 推拉力	≥3kgf	
LED Welding Standards/ LED 焊接品质	Offset Specifications/偏移规格: X Shift /X 轴 ≤ ±0.15mm; Y Shift/ Y 轴 ≤ ±0.15mm; Angle/角度 ≤ ±3°;	

Notes 备注 :

Fig 5-1 Push & Pull Test Equipment 推拉力测试设备 Fig 7-2 Push & Pull Test Method 推拉力测试方法

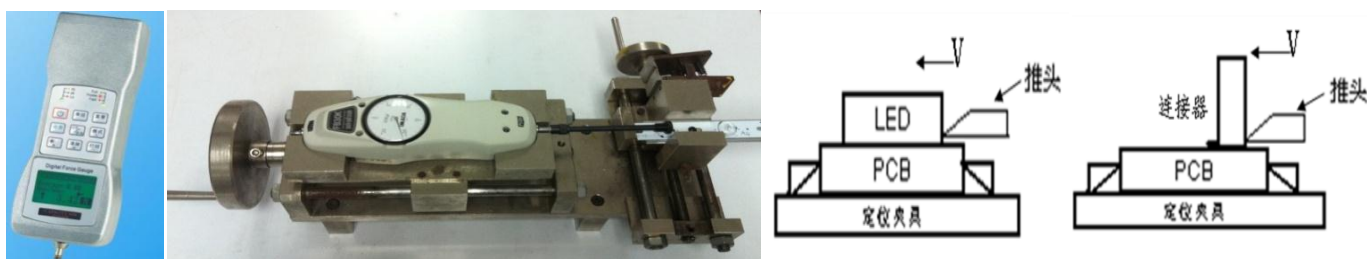

6.Packing Criterion/包装标准

6.1 Package Diagram /包装示意图

Fig 8-1 Package Diagram /包装示意图

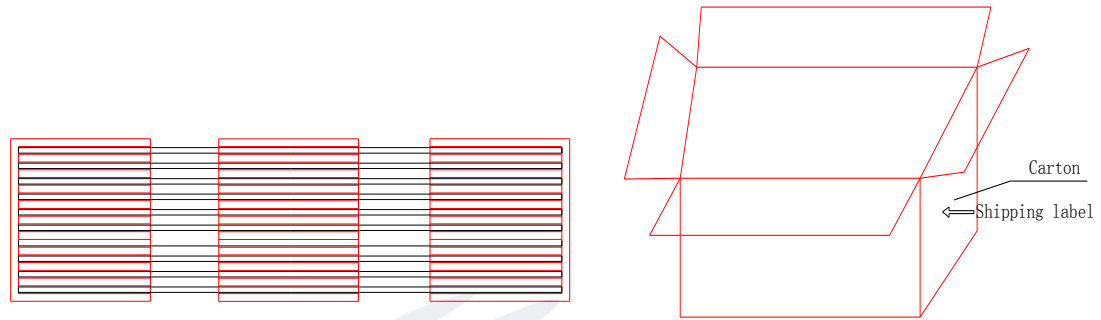

6.2 Carton silk printing/纸箱丝印

REFOND LOGO Pay attention to identify

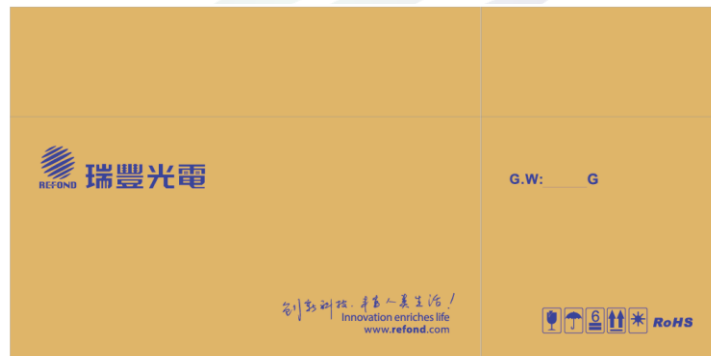

6.3 Label Form Specification/标签规格

 深圳市瑞豐光電子股份有限公司
REFOND SHENZHEN REFOND OPTOELECTRONICS CO.,LTD.

出货标签			
客户料号 /customer PN			
瑞丰料号/P.N			
色区/BIN CODE		亮度档/LM	
电压档/VF		色温/CCT	
显指/CRI		数量/QTY	
净重/N.W		日期/DATE	

7. Handling Precautions 产品使用注意事项

(1) LED operating environment and sulfur element composition cannot be over 100PPM in the LED mating usage material. This is provided for informational purposes only and is not a warranty or endorsement. LED 工作环境及与 LED 适配的材料中硫元素及化合物成份不可超过 100PPM. 这只是一个建议，不作任何品质担保。

(2) In order to prevent external material from getting into the inside of LED, which may cause the malfunction of LED, the single content of Bromine element is required to be less than 900PPM, the single content of Chlorine element is required to be less than 900PPM, the total content of Bromine element and Chlorine element in the external materials of the application products is required to be less than 1500PPM. This is provided for informational purposes only and is not a warranty or endorsement. 为了防止外界物质进入 LED 内部以造成 LED 的损伤，所处环境及所用套件等等，单一的溴元素含量要求小于 900PPM，单一氯元素含量要求小于 900PPM，溴元素与氯元素总含量必须小于 1500PPM. 这只是一个建议，不作任何品质担保。

(3) VOCs (Volatile organic compounds) emitted from materials used in the construction of fixtures can penetrate silicone encapsulants of LEDs and discolor when exposed to heat and photonic energy. The result can be a significant loss of light output from the fixture. Knowledge of the properties of the materials selected to be used in the construction of fixtures can help prevent these issues. Refond advises against the use of any chemicals or materials that have been found or are suspected to have an adverse affect on device performance or reliability. To verify compatibility, Refond recommends that all chemicals and materials be tested in the specific application and environment for which they are intended to be used. Attaching LEDs, do not use adhesives that outgas organic vapor. 应用套件中的挥发性物质会渗透到 LED 内部，在通电产生光子及热的条件下，会导致 LED 变色，进而造成严重光衰，提前了解套件材料能够避免产生这些问题。瑞丰反对使用任何对 LED 器件的性能或者可靠性有害的物质或材料，不管这些材料是已经证实了的还是仅仅怀疑有害。针对特定的用途和使用环境，瑞丰建议对所有的物质和材料进行相容性的测试。在贴装 LED 时候，不要使用能产生有机挥发性气体的粘结剂。

(4) Handle the component along the side surface by using forceps or appropriate tools; do not directly touch or Handle the silicone lens surface, it may damage the internal circuitry. 通过使用适当的工具从材料侧面夹取，不可直接用手或尖锐金属压胶体表面，它可能会损坏内部电路。

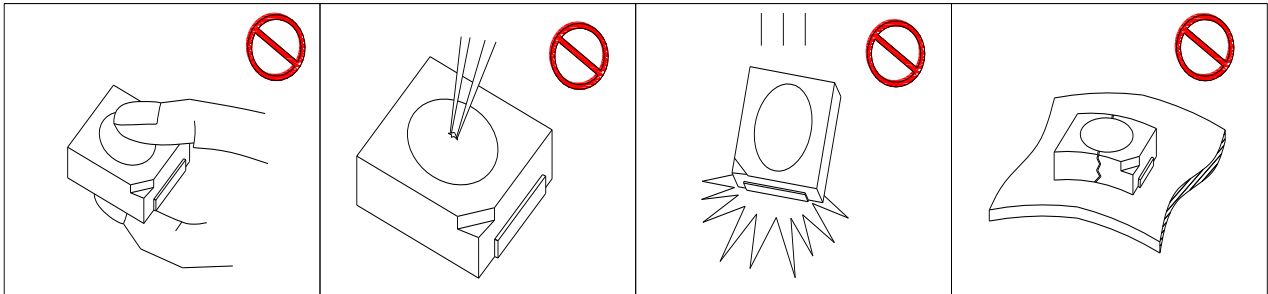

(5) In designing a circuit, the current through each LED cannot be exceeded the absolute maximum rating specified for each LED. In the meanwhile, resistors for protection should be applied, otherwise slight voltage shift will cause big current change, burn out may happen. The driving circuit must be designed to allow forward voltage only when it is ON or OFF. If the reverse voltage is applied to LED, migration can be generated resulting in LED damage. 设计电路时，通过 LED 的电流不能超过规定的最大值，同时，还需使用保护电阻，否则，微小的电压变化将会引起较大电流变化，可能导致产品损毁。电路设计必须保证只有在开启或者关闭的时候出现正向电压的变化，不要施加反压，否则会损坏 LED。

(6) Thermal Design is paramount importance because heat generation may result in the Characteristics decline, such as brightness decreased, Color change and so on. Please consider the heat generation of the LEDs when making the system design. LED 容易因为自身的发热和环境的温度改变而改变，温度升高会降低 LED 发光效率，影响发光颜色，所以在设计时应充分考虑散热问题。

(7) Compared to standard encapsulants, silicone is generally softer, and the surface is more likely to attract dust, requiring special care during processing. In cases where a minimal level of dirt and dust particles cannot be guaranteed, a suitable cleaning solution must be applied to the surface after the soldering of components. Refond suggests using isopropyl alcohol for cleaning. In case other solvents are used, it must be assured that these solvents do not dissolve the package or resin. Ultrasonic cleaning is not recommended. Ultrasonic cleaning may cause

damage to the LED. 与其他封装胶相比，硅胶通常较软，表面易吸附脏物，应用时应特别注意，当对产品洁净度要求较高时，回流焊以后需要采用恰当的清洗方式，我们推荐用异丙醇作清洗剂，如需要用到其他清洗剂，必须保证不会破坏封装体，超声清洗可能会对 LED 带来损害，不推荐这种清洗方式。

(8) Similar to most Solid state devices; LEDs are sensitive to Electro-Static Discharge (ESD) and Electrical Over Stress (EOS). 像其他的半导体电子器件一样，LED 对静电过流击穿非常敏感，需要做好防护。

9>.NO warping or twisting the Light Bar more than 10°. Forbidding holding the LED part or connector part when handling. 不得弯曲或者扭曲灯条超过10°，手持灯条时，不得触摸LED或者连接器部分。

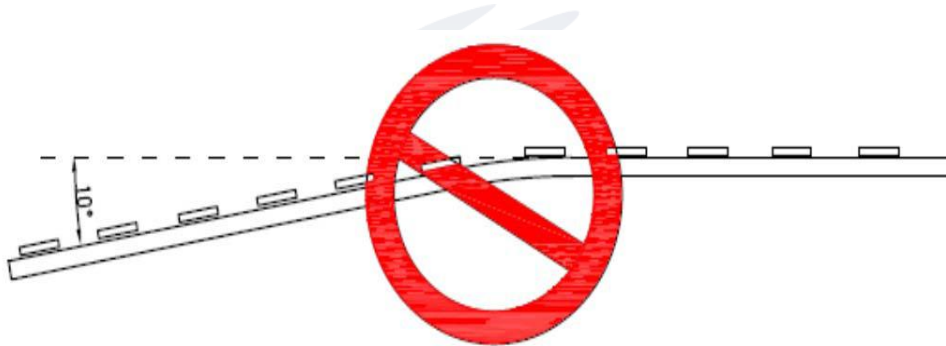

(10) Other points for attention, please refer to our relevant information. 其它注意事项请参照瑞丰相关资料。

REFOND

Version History/修订历史

Date日期	Revisor修订者	Version版本	Verifier审核	Remarks备注
2021-4-13	范锐文	E/0	邱涛	The first edition





Declare 申明

This specification is written both in English and in Chinese and the latter is formal.

产品规格书以中英文方式书写，若有冲突以中文版本为准。